



# Granulate Conveyor

Standard granulate conveyor featuring a robust design and high-quality stainless steel finish.



### Technology and Quality:

- Particularly suitable for engineering plastics
- Can be integrated into production and processing systems
- Quick fastener for integrated filters
- Lockable cover
- Large inlet opening
- Optional discharge flange sizes
- Ideal and easy access for cleaning

### Optionally Available:

- Mounted filter with pneumatic dedusting and fan
- Screw compactor as empty-bag compactor
- Dropping of empty bags with bag clamp for a garbage bag to ensure low-dust disposal of empty bags.
- Inspection glass and gauntlets for an even higher level of occupational safety when slicing the bag
- ATEX execution for zones 22, 21, 2 and 1

### Areas of Application:

- Powders
- Granules
- Additives
- Chemical products

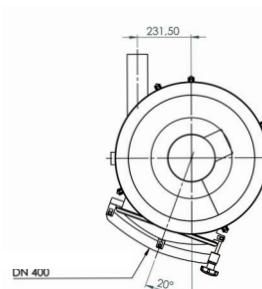
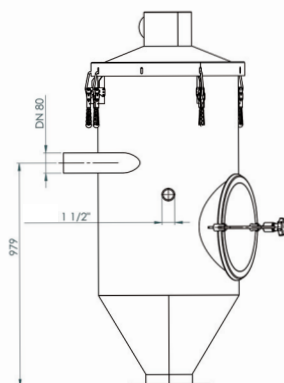
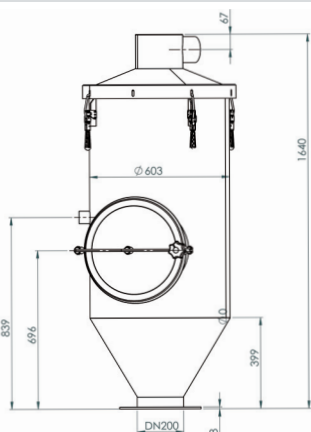

### Technical Configuration According to the Customer Requirements:

Performance, volumetric capacity, materials used and dimensions in height and width as well as dimensions and material of the discharge flange, filter size and filter material are provided depending on the configuration wish.